

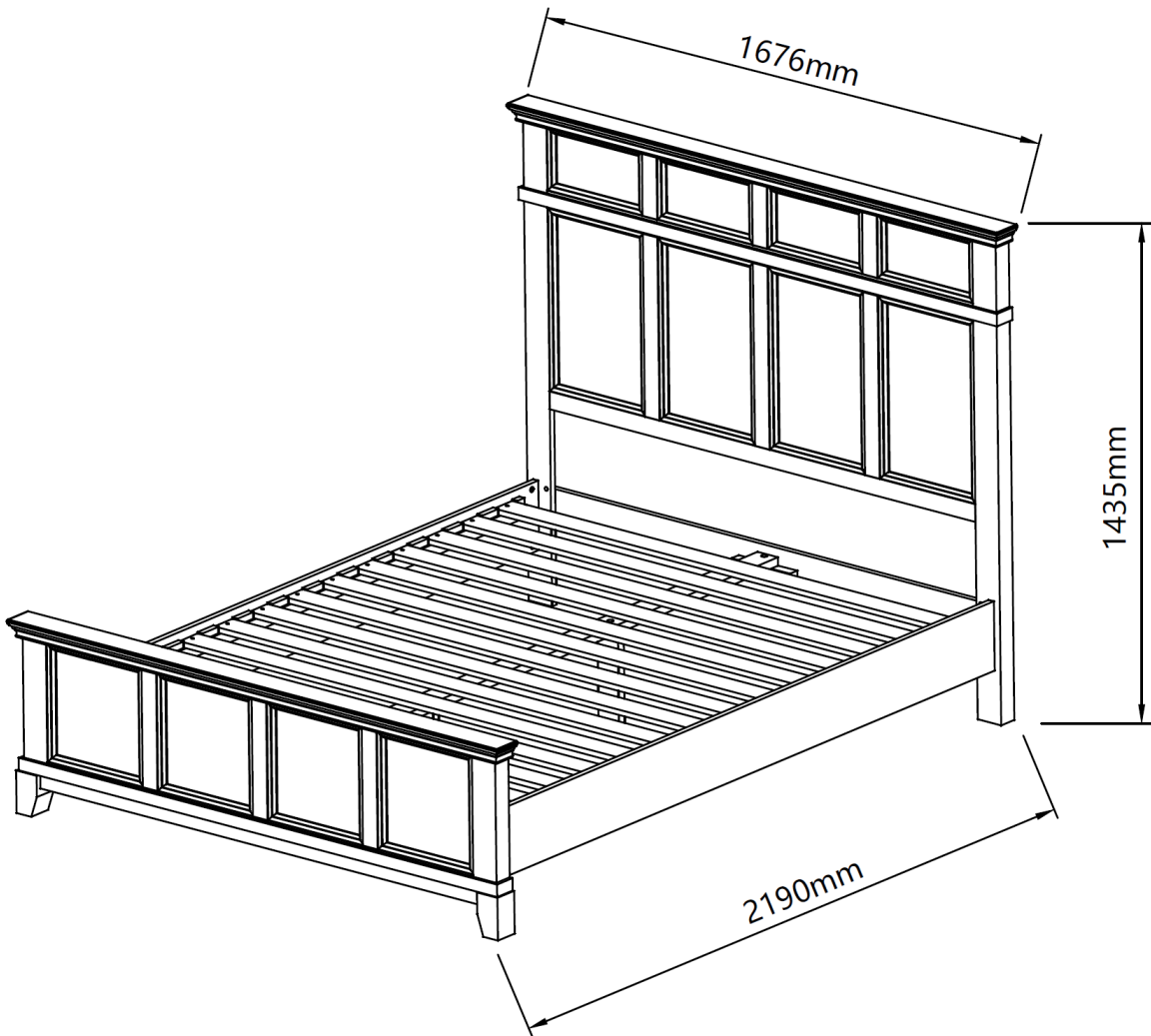

ASSEMBLY INSTRUCTION
ELARA QUEEN BED
ITEM CODE 81478





Imported by Amart Furniture Pty Ltd, Brisbane ,Qld Australia.
For any assistance with assembly or for missing parts please phone Amart
Furniture, Customer Service Free call 1800 937 566

PRE-ASSEMBLY PREPARATION

Before you start:

1. Choose a clean, level, spacious assembly area. Avoid hard surfaces that may damage the product
2. Take care when lifting. Product should be assembled as near as possible to the point of use
3. Ensure that you have all required contents for complete assembly
4. Always read the assembly instructions carefully before beginning assembly.
5. Keep all hardware parts and packaging out of reach of small children.
6. Do not over tighten the screws and bolts as this may damage the threads

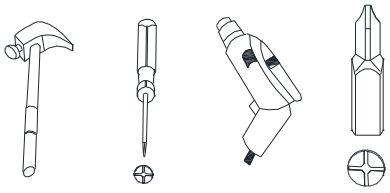
	
ALLOW 60 MINUTES	2 PEOPLE REQUIRED
	
TOOLS REQUIRED	

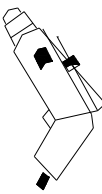
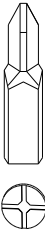



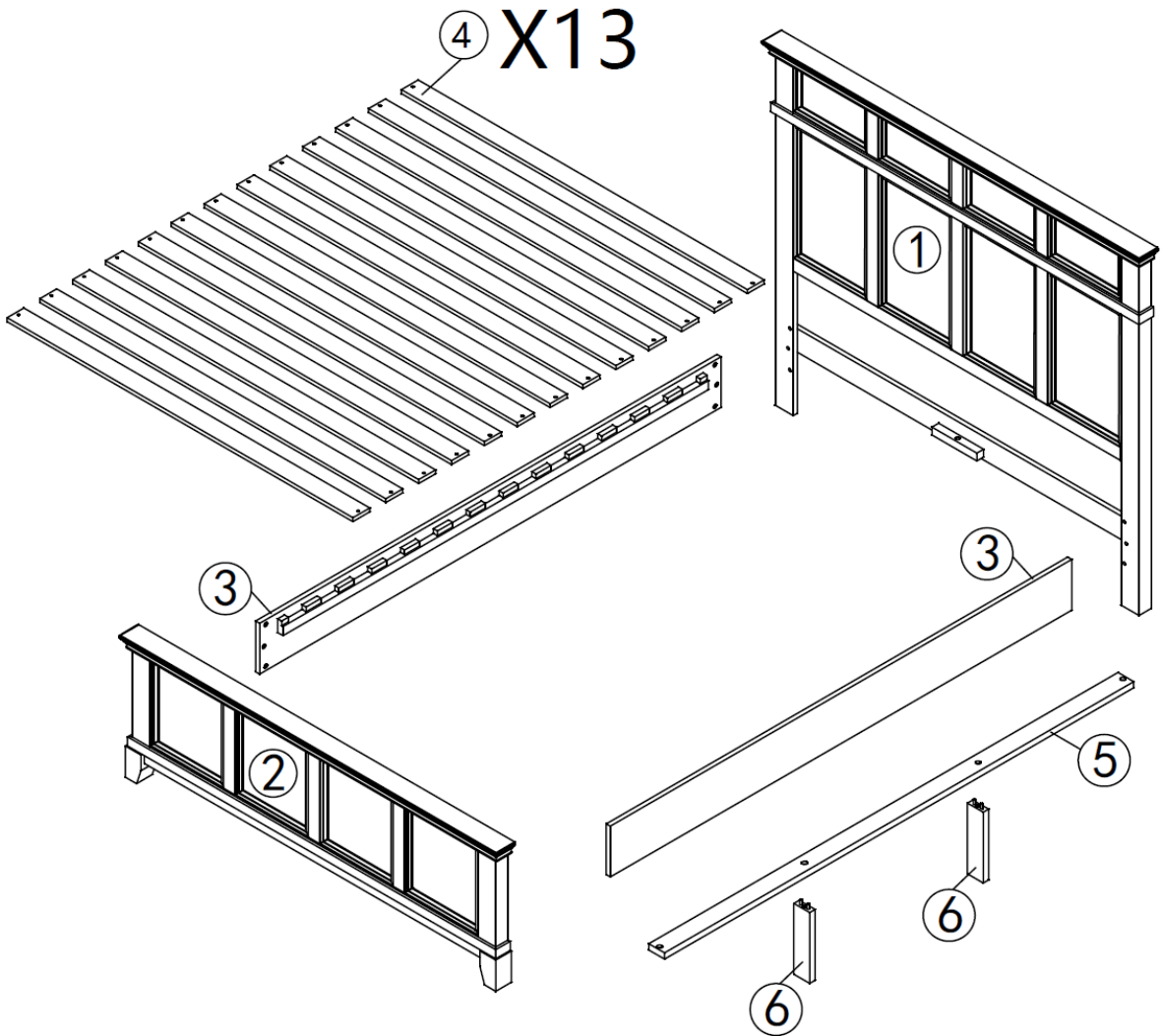

		<p>We recommend using a screwdriver to put this item together. However if you choose to use a power drill it must be used on LOW SPEED (LOW TORQUE) as too much pressure could damage the product</p>
---	---	--

PARTS LIST

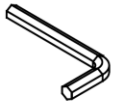

1	HEADBOARD
2	FOOTBOARD
3	SIDERAIL

4	SLATS
5	CENTRE RAIL
6	SUPPORT LEGS

A. M8X20mm  AX12	B. M8X32mm  BX4	C.  CX16	D.  DX12	E. M5  EX1
F. M4X28mm  FX26				

1.

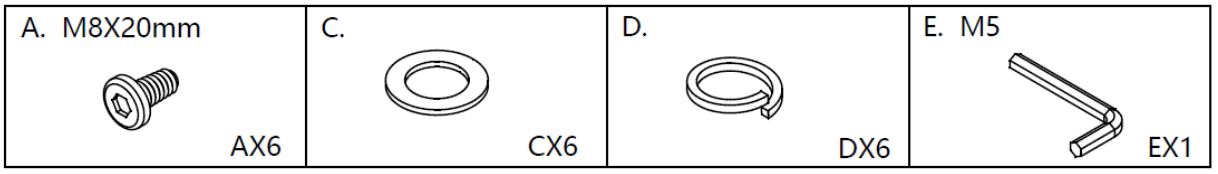

- Attach one siderails (3) to headboard(1) and footboard (2) with flat washer (C) , lock washer (D) and bolts (A)
- Do not tighten with allen key (E)

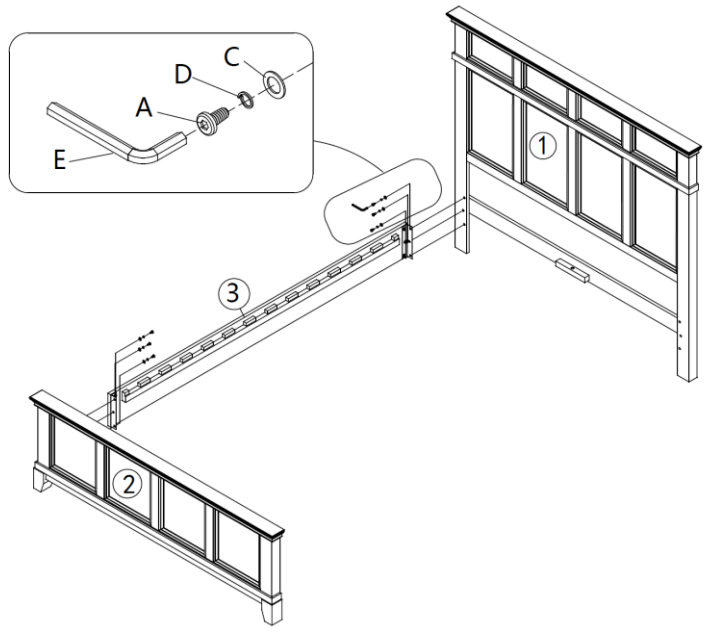

2.

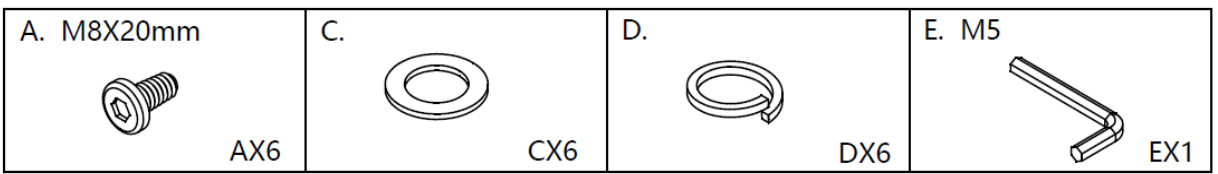

- Attach the other siderails (3) to headboard(1) and footboard (2) with flat washer (C) , lock washer (D) and bolts (A)
- tighten all bolts (A) with allen key (E)

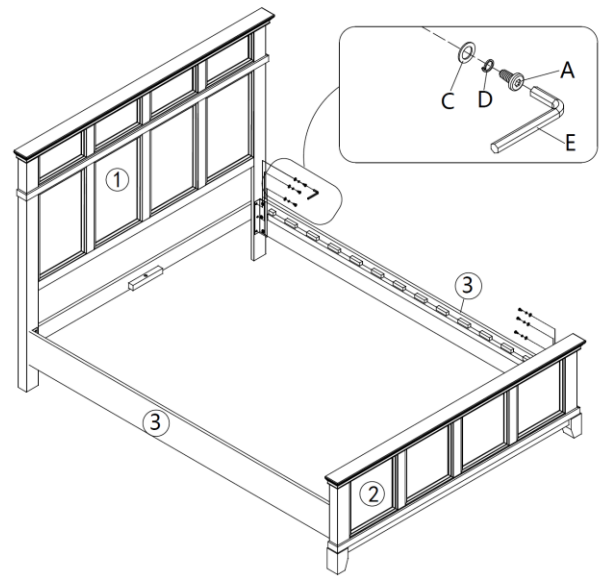

3.

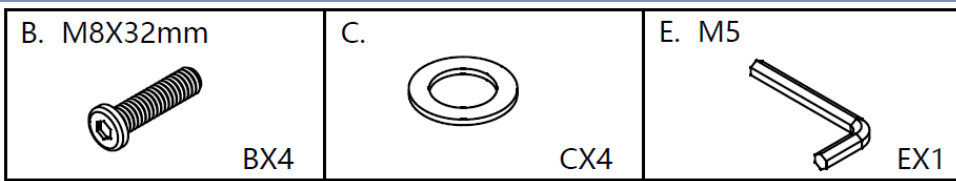

- Attach support legs (6) to centre rail (5) with flat washer (C) and bolts (B)
- Attach centre rail(5) to headboard support bar (1) footboard support bar (2) with flat washer (C) and bolt(B)
- Tighten with allen key (E)

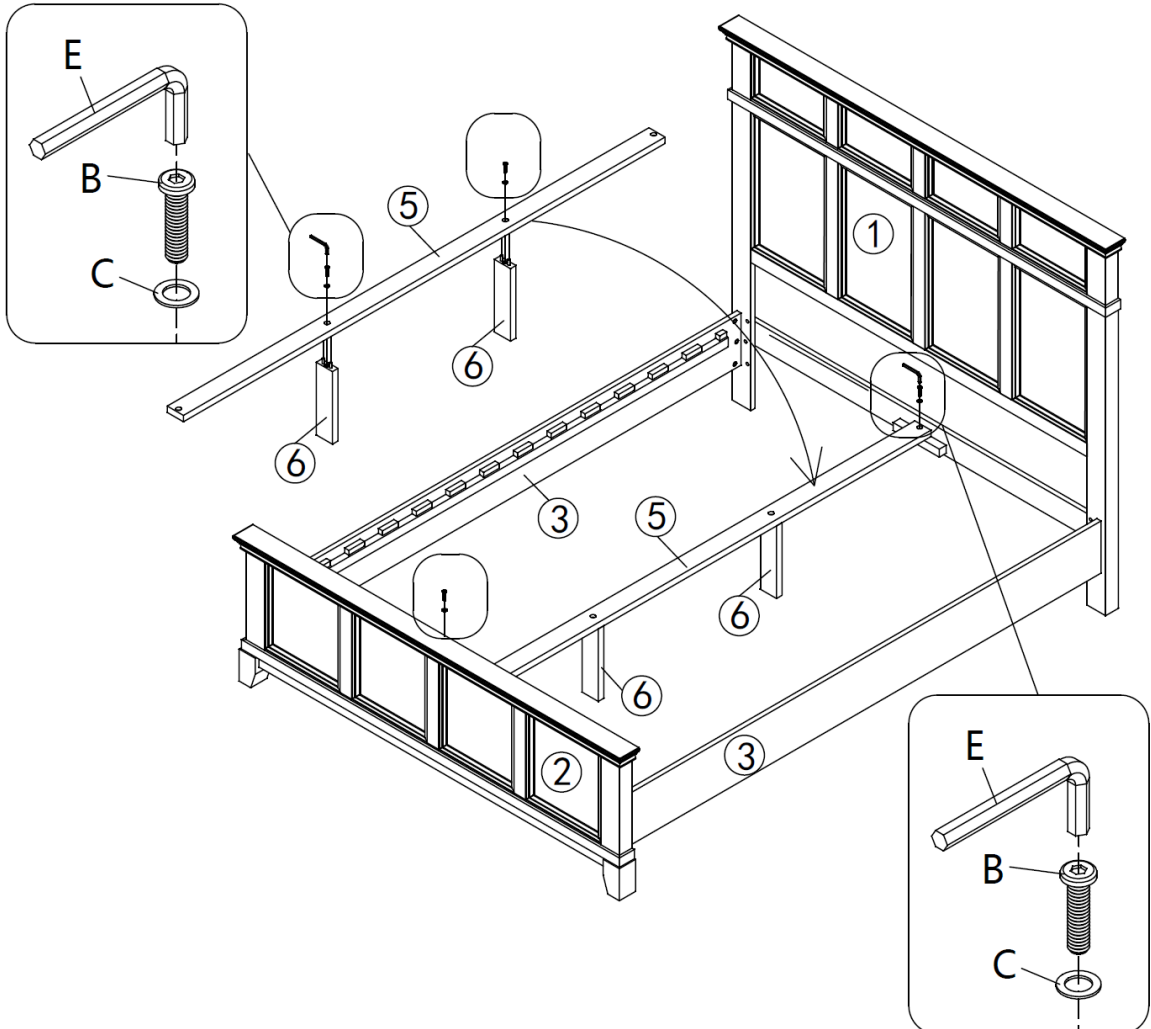

4

F. M4X28mm

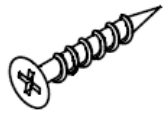

FX26

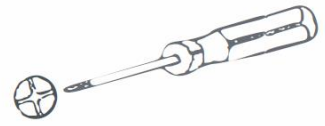

- Attach slats (4) to siderail (3) using screws (F).
- Use Screwdriver or Power Drill on Low Speed.

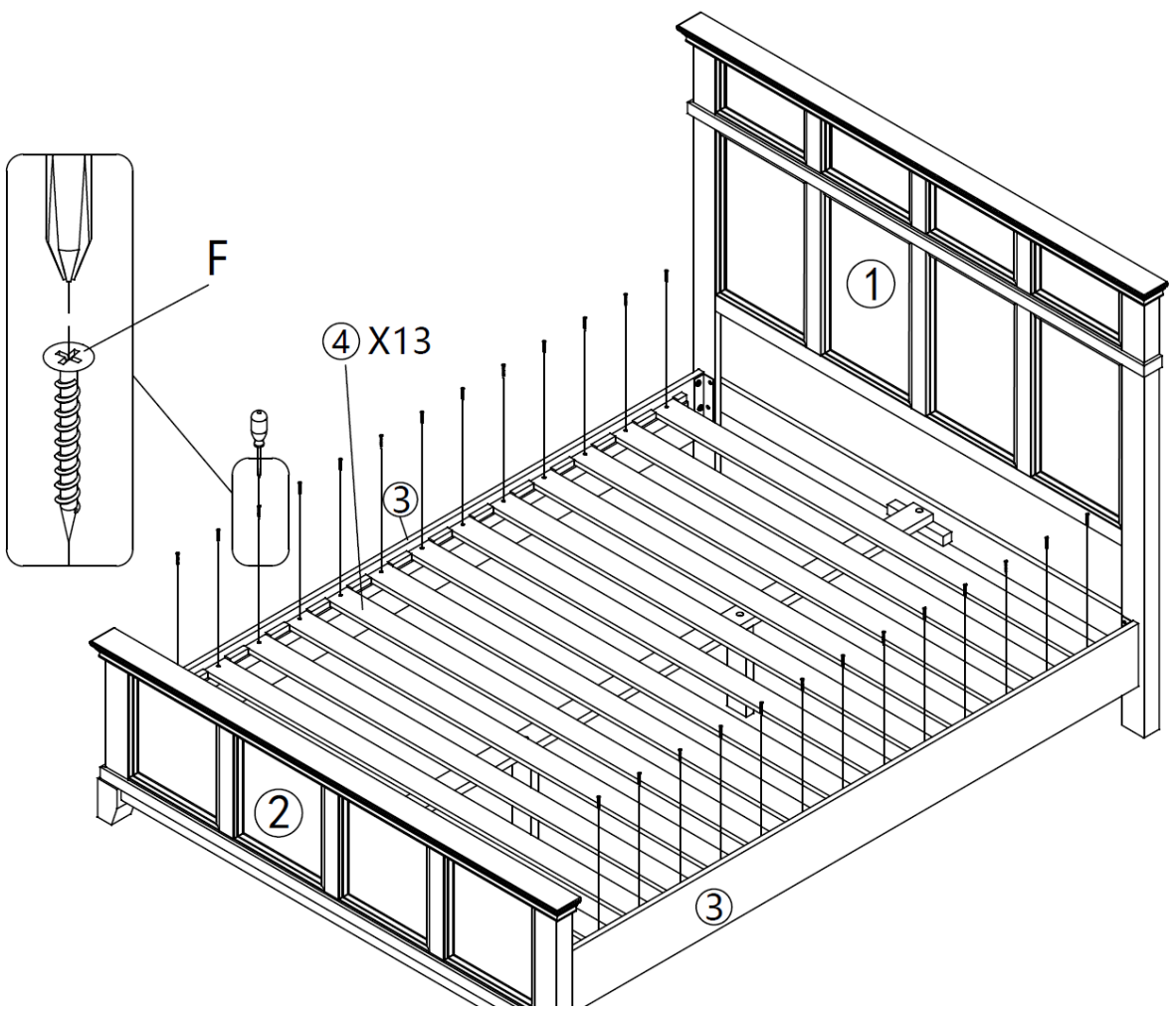

ASSEMBLY IS COMPLETE

CAUTION

Always Lift Your Bed When Moving /Relocating -
Do Not Drag. Dragging Can Cause The Centre
Support Legs To Bend/Break.

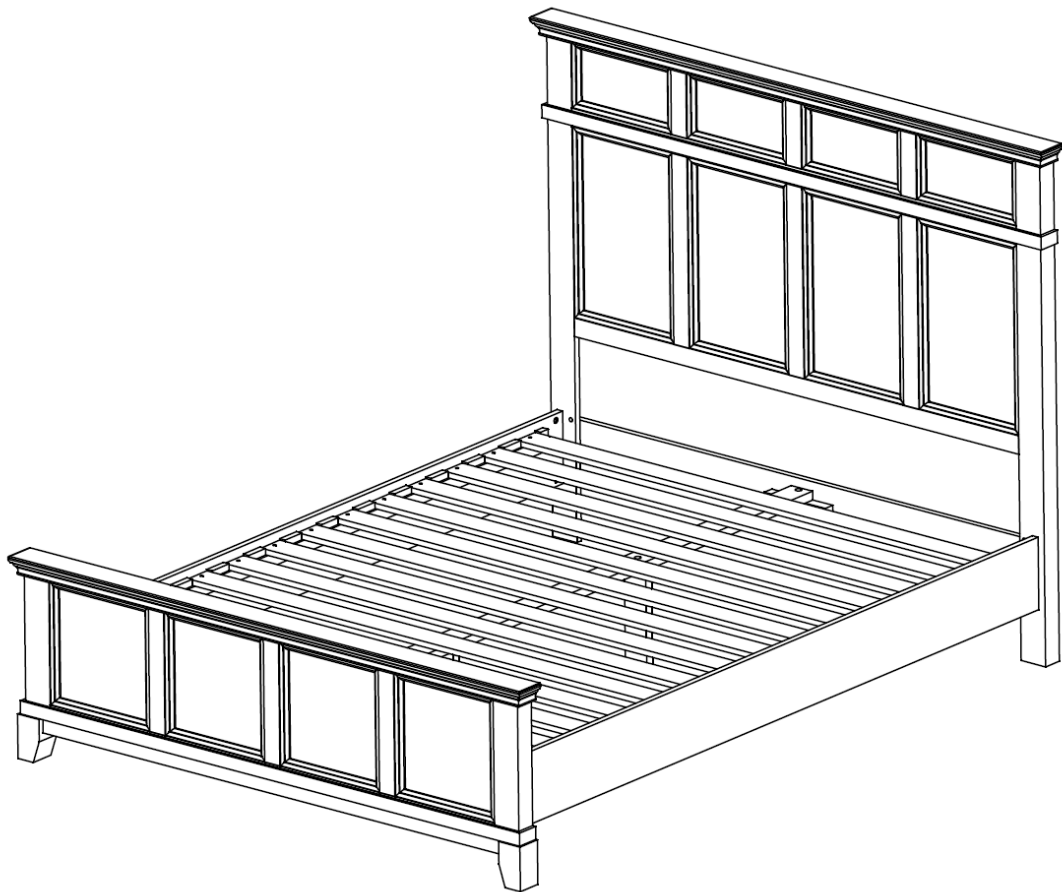

Care and maintenance



- A multi-step finish is applied to all our furniture, but all wood comes from nature. Because of this, there will be natural variations in surface texture and grain like knots, mineral streaks and sap runs that may affect the finish. These differences in character are not defects, but distinctions that make each piece of furniture unique.
- Our furniture is built to last. Following these steps for basic care should protect your investment for years to come.
- Dust frequently with a clean damp lint-free cloth. This will help remove abrasive build up which can damage a finish over time.
- Do not place hot objects on any furniture surface. Always use a hot plate or placemat. Laminate and lacquer finishes on table tops provide added scratch and heat resistance to our furniture, but they can still be damaged without proper care.
- Avoid exposing your furniture to strong sunlight, heat outlet, open windows or dampness. Prolonged exposure to direct sunlight can fade the finish of your furniture, while extreme temperature and humidity changes can cause cracking or splitting.
- Do not expose your furniture to any liquids. Never allow water to sit on your furniture. Alcohol, nail polish and perfume are also dangerous as they will dissolve the lacquer finish on contact and may require professional repairs.
- Do not allow plastic to come in direct contact with your furniture. Chemicals in the plastic of placemats etc may soften and mark the finish if left in contact with the furniture for a period of time.